

(12) UK Patent Application (19) GB (11) 2 103 943 A

(21) Application No **8220867**

(22) Date of filing **19 Jul 1982**

(30) Priority data

(31) **8122378**

(32) **21 Jul 1981**

(33) **United Kingdom (GB)**

(43) Application published

2 Mar 1983

(51) **INT CL³**

A63F 3/02 G08C 21/00

(52) Domestic classification

A6H 3A 3C2 3C4

(56) Documents cited

GB 1348451

GB 1273117

(58) Field of search

A6H

G4H

(71) Applicant

SciSys-W Limited,

(Hong Kong),

1801 Admiralty Centre,

Tower II,

18 Harcourt Road,

Hong Kong

(72) Inventors

Philip Thomas Blenkinsop,

Tony Chung Chi-Ming,

Peter William Lee,

Rupert Leslie Alexander

Goodings

(74) Agents

Lloyd Wise Tregear and

Co.,

Norman House,

105—109 Strand,

London,

WC2R 0AE

(54) **Electronic game board**

(57) The board, e.g. a chess board, senses the position of and nature of each playing piece 20. Each playing piece has an electrical resonant circuit 30 tuned to a particular frequency to distinguish it from the other pieces, and each board play position has a transmitter 22, which emits a pulse of electromagnetic radiation to induce resonance in the resonant circuit of a

piece positioned on that board position, and a receiver 24. A discriminator determines the resonant frequency received by each receiver and thereby determines the nature of the particular piece or absence of a piece on that position. The discriminator determines the time span of a set number of received oscillations, e.g. by gating the count from a regular oscillator and the board stores the positions of the pieces.

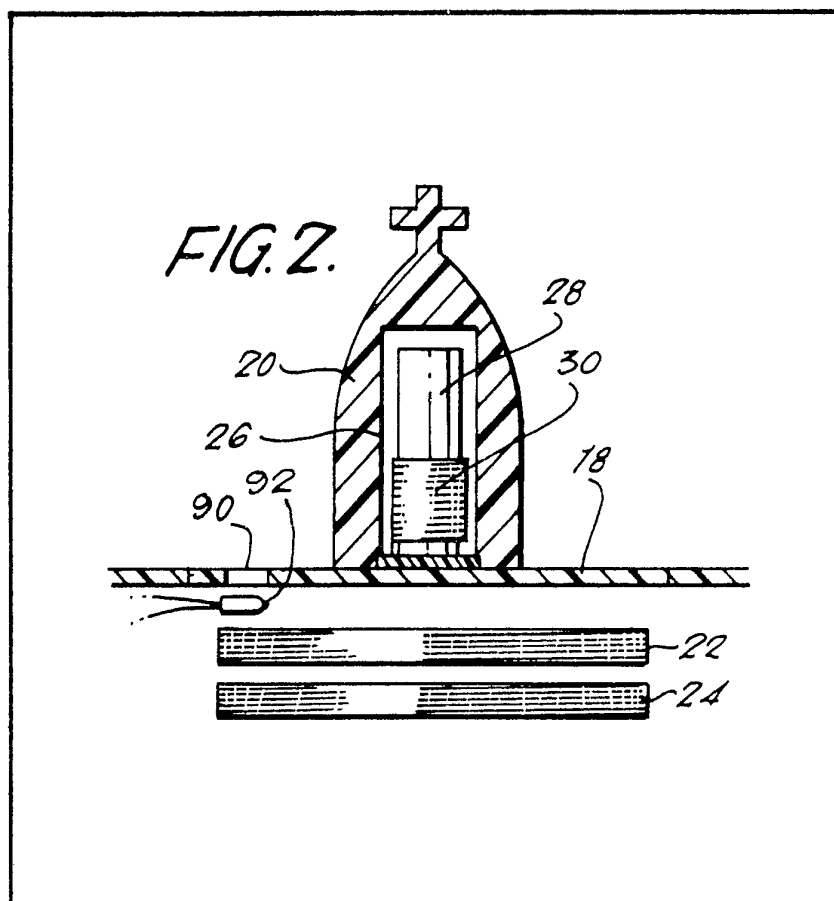

GB 2 103 943 A

1/7

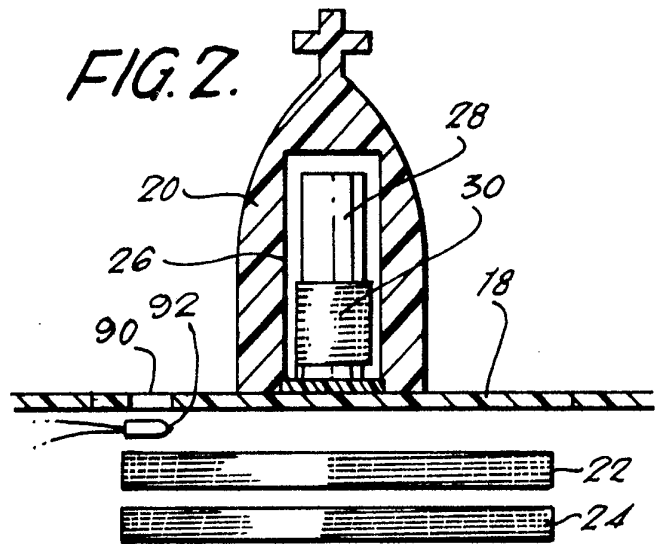
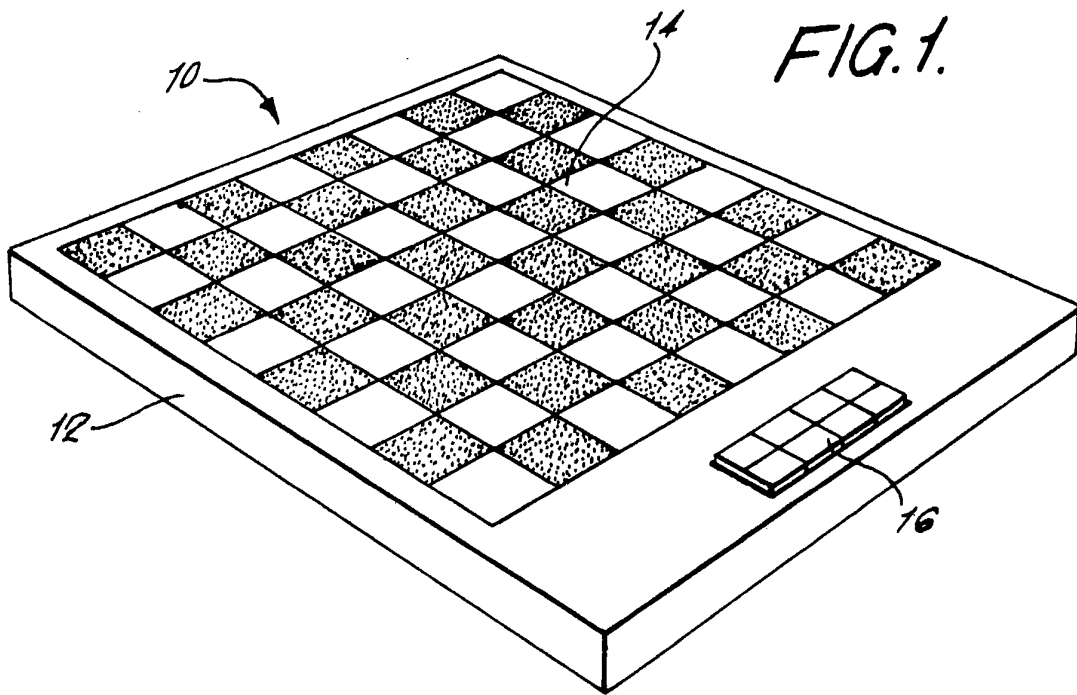
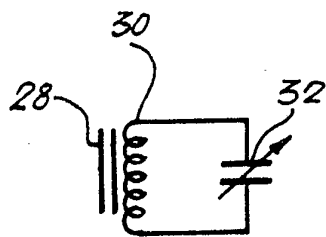
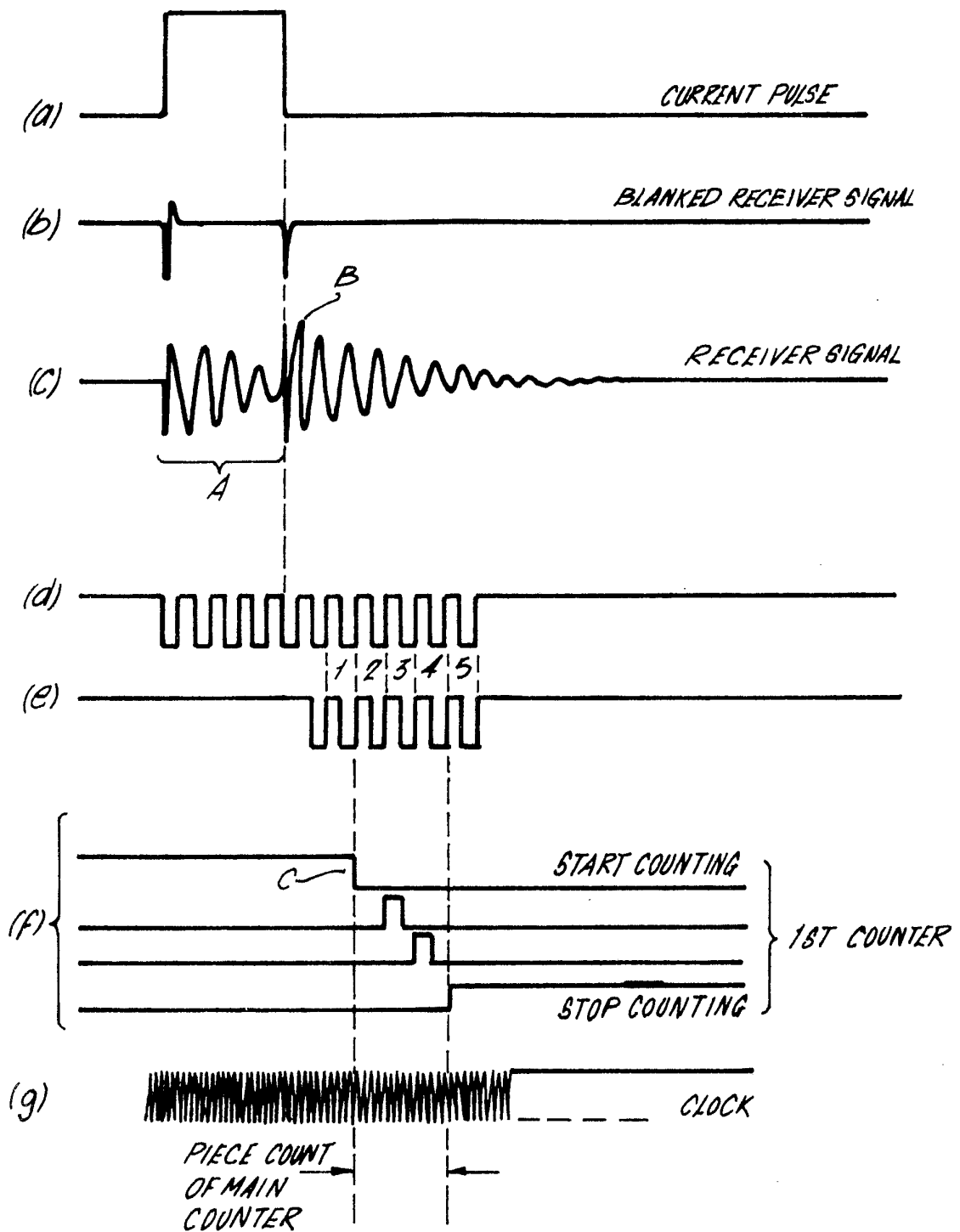

FIG. 2A.



2/7

FIG. 3.



3/7
FIG. 4.

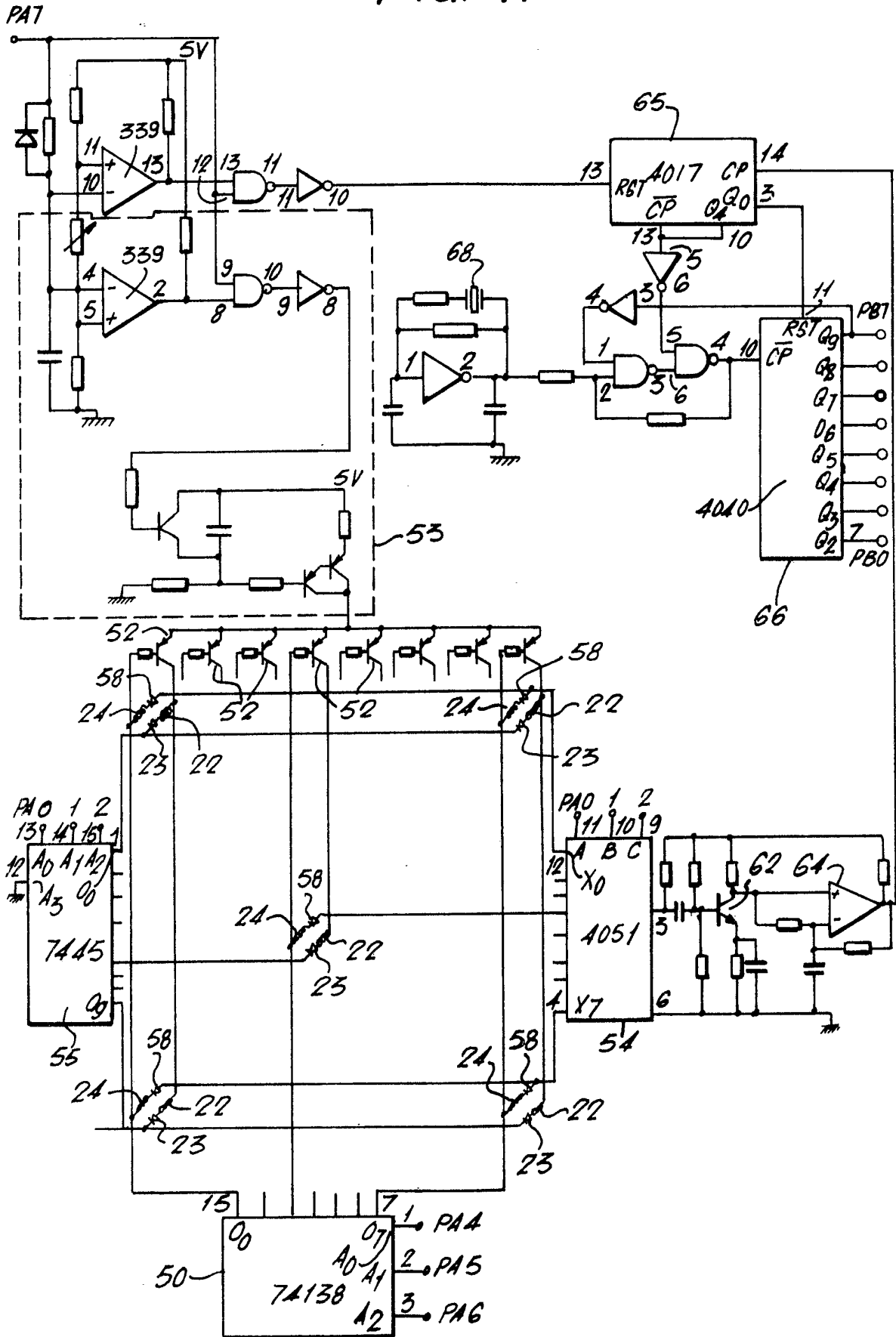

4/7

FIG. 5.

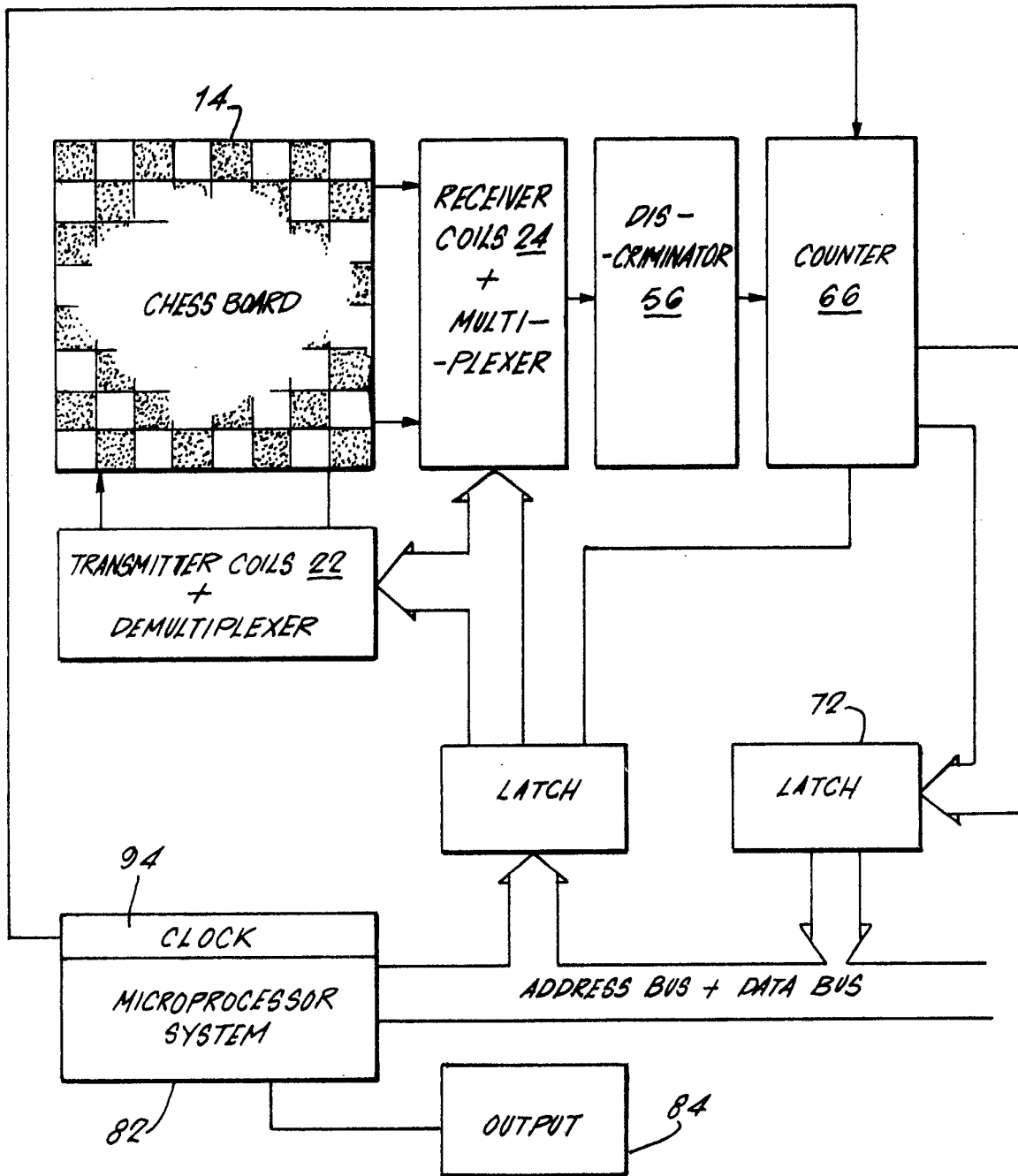
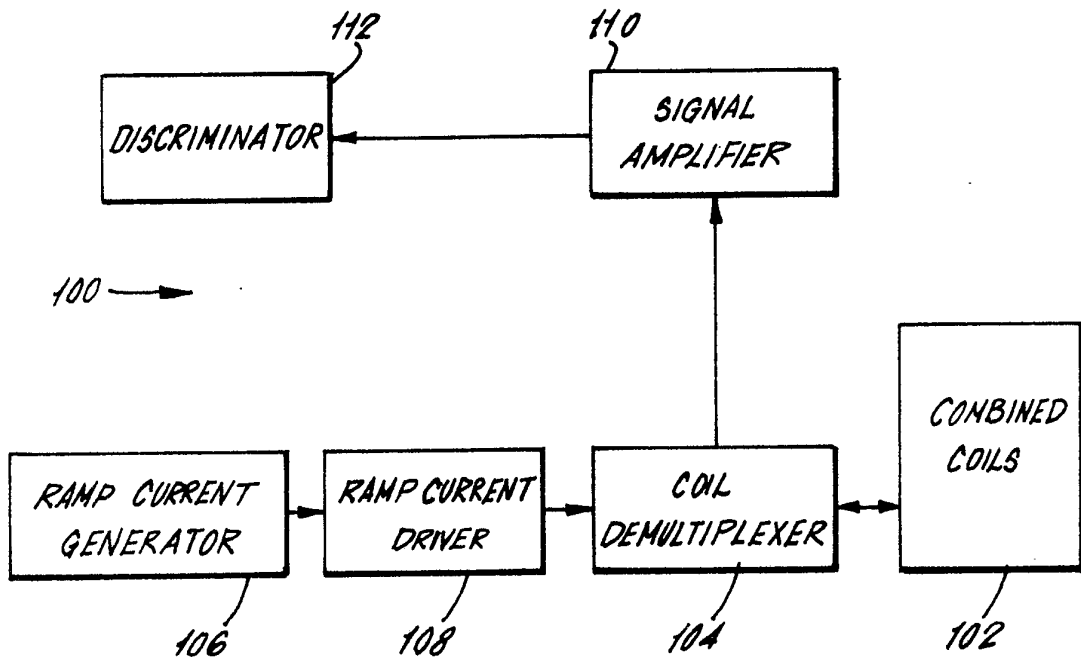

FIG. 6.



6/7

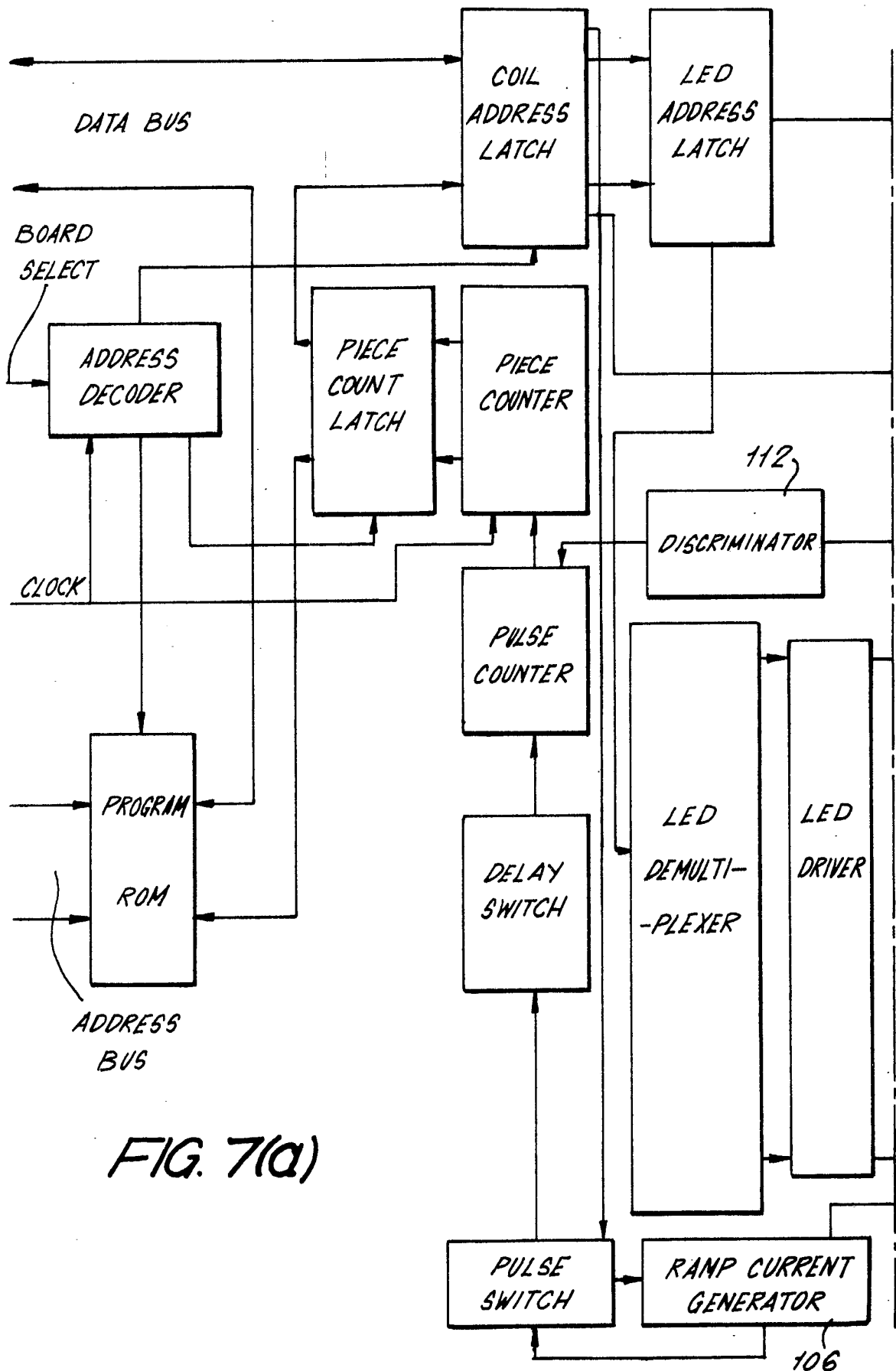
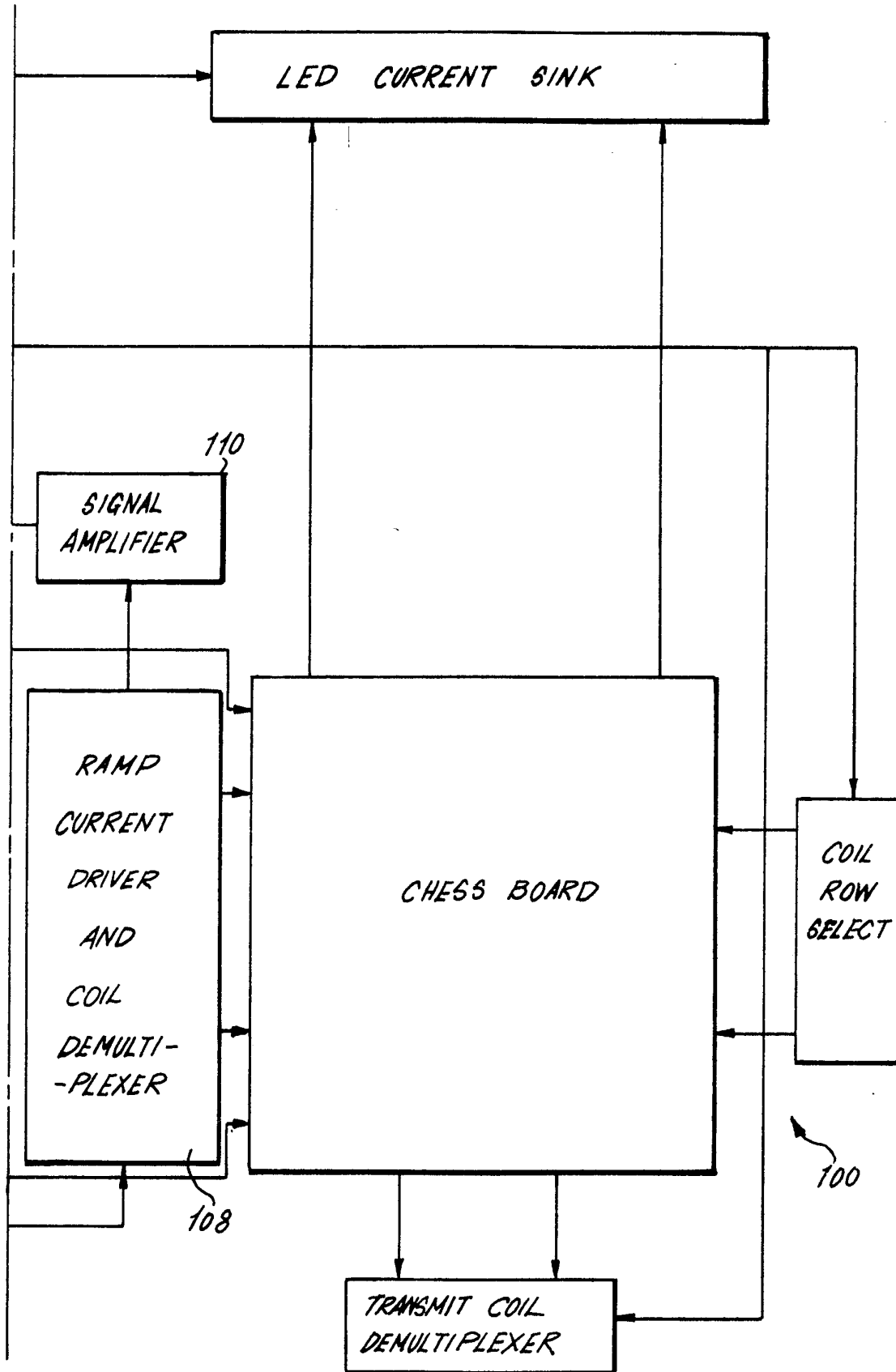

FIG. 7(a)

7/7
FIG. 7(b)



SPECIFICATION

Improvements in board games

This invention relates to board games and in particular board games where the role of one of the players is taken over by an electronic computer.

5 With the increase in sophistication of integrated circuit chips, it has become readily possible to provide in the small and compact space of a game a sufficiently powerful computer to enable a high standard chess playing program to be incorporated. As a result, it has become possible for keen chess players to obtain at a reasonable cost a chess playing game of a reasonable size where the role of one of the two players is taken over by the computer program. 5

10 Various types of games of this nature have been sold. One consists predominantly of a box of electronics having input buttons to inform the computer of the player's moves and a display to show the player's moves and the computer's response. The display will show positions of pieces to be moved by co-ordinates for the board positions, e.g. by numbering the rows of a chess board from A to H and by numbering the columns 1 to 8. In this type of board it is possible to make mistakes by incorrectly interpreting the positions shown in the display when moving the pieces on the corresponding visual board which a player uses. In addition, it is also possible for the visual board not to correspond to the equivalent information stored in the computer memory as to the up-to-date position of the chess pieces. Thus, it is found that players can very easily make errors particularly upon the capture of a chess piece such as leaving the captured chess piece on the board and taking off the capturing chess piece. 10 15 20

An alternative approach has been to provide a board in which each board position is provided with some form of sensing means to determine the up-to-date positions. Thus, in one embodiment, the board surface has been in the form of electrical switches which have sensed the presence of a piece by virtue of the weight of that piece which closes a switch in that position. This development has certain disadvantages. Thus, the board cannot recognise the rank of a particular chess piece on a square but can only determine the presence or absence of a chess piece on that square. Therefore, it is just as easy for errors to occur in this type of board and equally a player cannot simply set up a position half way through a game for practice without entering into the memory of the computer the actual positions and ranks of the chess pieces. The other disadvantage of such boards is that a special board surface is required which means that a player does not play on a natural non-distracting flat board. 25 30

It is therefore an object of this invention to provide a board for a board game such as chess where the position and nature of each piece on the board is sensed automatically.

According to the invention there is provided a board for a board game having a surface on which playing pieces are arranged to be moved by players over a range of discrete board positions according to the rules of the game, each playing piece being provided with an electrical resonant circuit whose frequency is distinguishable from other discrete pieces, each discrete board position being provided with a transmitter capable of emitting a pulse of electromagnetic radiation to induce resonance in the resonant circuit of a piece positioned on that board position, and with a receiver for detecting the presence or absence of returning electromagnetic resonant radiation depending upon whether or not a piece is positioned on that board position, a discriminator for determining the resonant frequency or lack of resonant frequency received by the receivers to determine the nature of the particular piece or absence of a piece on that discrete board position, means for storing the up-to-date board positions of each piece on the board, and means for determining a move made by a player moving a piece from one board position to another. 35 40

45 Since each piece has a characteristic resonance for its resonant circuit, it is thus possible for the game to detect firstly the presence or absence of a piece on each discrete board position and secondly, by determining the actual resonant frequency, the nature of the piece on that board position. Thus, with such a board, a player can simply play as if he were playing with another human competitor and manually move pieces on the board when it is his turn according to the rules of the game. The board will then automatically sense the move he has made and can display its own response, e.g. by illuminating indicator lights at the initial and final positions to show the required move. Then the player moves the piece according to those indications and the board will sense when the move has been correctly selected. In the event that the player makes a mistake and moves the piece to the wrong board position or, during capture, leaves the wrong piece on the board, this will be detected by the board which can then give an error indication. 50 55

Also according to the invention there is provided a board game comprising a board on the surface of which playing pieces are arranged to be moved by players over a range of discrete board positions according to the rules of the game, each playing piece being provided with an electrical resonant circuit whose frequency is distinguishable from other discrete pieces, each discrete board position being provided with a transmitter capable of emitting a pulse of electromagnetic radiation to induce resonance in the resonant circuit of a piece positioned on that board position, and with a receiver for detecting the presence or absence of returning electromagnetic resonant radiation depending upon whether or not a piece is positioned on that board position, a discriminator for determining the resonant frequency or lack of resonant frequency received by the receivers to determine the nature of 60

the particular piece or absence of a piece on that discrete board position, means for storing the up-to-date board positions of each piece on the board, means for determining a move made by a player moving a piece from one board position to another, and means for selecting and indicating the game's response move to a move made by a player according to preselected criteria stored in the game's memory.

5 The invention is particularly applicable to chess. In particular for chess, the invention has the very useful advantages that a player can simply set up a chess position on the board and start right-away to play since the game itself will be able to detect the positions to which all the pieces are set and could of course give an indication of a gross error, e.g. both white or black bishops on the same colour square. No separate manual feeding into the board's memory of each piece in each position is necessary. Further with chess, there is the advantage that as the game progresses and one reaches a point where pawns are promoted, the player has the opportunity to promote the pawn to whatever type of piece he feels appropriate simply by replacing the pawn with the desired piece.

10 The invention is not however limited to chess games or even for that matter games which are played on a board made up of columns and rows of discrete board positions such as draughts, checkers, go and so on. Instead, the invention can be applied to any type of board game where pieces are moved from one position to another in response to preceding moves and a set of rules. Indeed, a board game according to the invention could be arranged to play a wide selection of games upon appropriate provision of the different sets of pieces and different programs for programming the memory. For simplicity hereinafter reference will be made solely to the game of chess but, unless the context specifically requires otherwise, references to chess are to be construed as embracing any board game where discrete pieces are moved around discrete board positions.

15 In each piece the electrical resonant circuit is conveniently constituted by an inductor and capacitor joined in a loop. The inductance is preferably a coil of wire wound round a ferrite core to concentrate the flux and so the ferrite core is normally mounted upright in the piece, the coil preferably being positioned near the bottom of the piece as near to the board surface as possible. Conveniently the capacitor is made adjustable so that the circuit associated with each piece can be tuned reasonably accurately to the particular resonant frequency allotted to that piece.

20 Even though there may be a large number of different pieces to be detected uniquely, this can readily be managed by using a range of frequencies. In the case of chess, if one treats each white pawn as the same and each black pawn as the same, there are 12 different chessmen to detect and this can readily be achieved by spreading the frequencies of the circuits of those chessmen geometrically evenly over a range. Indeed it would also be possible if desired to distinguish each pawn uniquely making a total of 32 chessmen.

25 With most board games and certainly with chess, there are a relatively large number of discrete board positions. Indeed, in chess there are 64 board positions made up of a matrix of 8 columns and 8 rows. Each board position will therefore require its own transmitter and receiver can be in the form of separate electrical coils, the transmitter coil preferably being mounted closer to the board surface than the receiver coil. However, one coil can be used to function both as the transmitter and the receiver. In normal operation, the game will continuously scan over all of the board positions one at a time. For good signal/noise ratios, the associated pair of transmitters and receivers for each board position where two separate coils are provided are activated synchronously. Because the board has to scan over a large number of positions, it is desirable that this be achieved by multiplexing so as to reduce the number of connections which need to be made to the various coils. This also enables all of the receivers to use common discriminator circuitry.

30 The transmitter coils and receiver coils can be connected row by row or column by column either in series or in parallel to be energised column by column or row by row. Series connection for each row or column has the advantage of reducing the number of connections to be made to the board but the disadvantage of series connection of the receiver coils is interference from the resonant circuits of chessmen occupying board positions further along the row or column. Parallel connection for each row or column has the disadvantage of doubling the number of connection wires and in addition for the receiver coils there is the undesirable side effect that a large proportion of the received signal can be re-radiated by the other coils connected in parallel.

35 According to a preferred embodiment of the invention therefore full matrix multiplexing of the board is made. This is achieved both for the transmitter and receiver coils by connecting them in parallel and providing in series with each coil a diode only one of which is made conductive in any one row or column of receiver coils connected in parallel at any one time. This avoids the problem of re-radiation of the received signal.

40 Alternatively the transmitter coils could be connected in series for each row or column but in addition adjacent coils in a row or column could be connected to alternate driving circuits so as to reduce interference between adjacent board positions.

45 In one preferred embodiment of the invention a single coil is used both for the transmitter and receiver. Thus during transmission the receiver coil is not functioning as a receiver and vice versa. Therefore a single coil can be used for transmitting the pulse of radiation and can then function to receive and pick-up the returned resonant radiation to function as the receiver. The switch of the coil

from one function to the other can be achieved by a demultiplexer circuit instantaneously after the pulse of radiation has been emitted.

- According to a preferred embodiment of the invention the discriminator determines the frequency received by the receiver by determining the time span of a set number of received oscillations. In turn
- 5 this time span can be determined simply from the count made by a counter fed with regular pulses 5
from an oscillator which is switched on at a particular receiver oscillation and switched off after a set
number of received oscillations. In practice, it is preferred that all oscillations received from a piece as a
result of the front edge of the pulse be ignored and that only the oscillations received from a piece as a
result of the rear edge of the pulse be used by the discriminator. It is therefore possible for the
- 10 transmitted pulse to be a ramp pulse which increases progressively and has an abrupt rear edge. In 10
addition it is further preferred that at least the first oscillation of this also be ignored since that
particular oscillation is subject to variations. Therefore the counter should be used to determine the
time interval from the beginning of say the second oscillation through say to the end of the fourth
oscillation induced as a result of the rear edge of the pulse emitted by the transmitter.
- 15 Examples of electronic chess games according to the invention will now be described with 15
reference to the accompanying drawings, in which:
- Figure 1 is a perspective view of the game;
- Figure 2 is an enlarged section through a board position and a chessman standing on that
- 20 position;
- Figure 2A is a circuit diagram of the circuit within each chessman; 20
Figure 3 is a diagrammatic graph illustrating how the resonant frequency of a chessman is
determined;
- Figure 4 is a block diagram showing the circuitry associated with the game for detecting
- 25 positions of each chessman on the board;
- Figure 5 is a block diagram showing the operation of the electronic chess game; 25
Figure 6 is a block diagram detail illustrating a modified chess game using a single coil both as
the transmitter and the receiver; and
- Figure 7 is a block diagram of the operation of the whole modified chess game.
- Figure 1 shows the chess game 10 according to the invention. This comprises a box 12 in which
- 30 the various electronics for operating the game are housed. On the top surface of this box 12 is marked 30
out a chess board 14. This is in conventional form for a board and consists of a matrix of 8 rows of 8
columns of squares with alternate squares marked white or black. Although not shown in Figure 1, a
set of chessmen are provided and they will be positioned on the board and moved around the board
according to the standard rules of chess.
- 35 The board also has a set of keys 16 controlling electrical switches to enable a player to input 35
information such as for example whether he or the computer will play black or white and the level or
standard at which the computer is designed to play.
- Reverting now to Figure 2 this shows in cross-section an individual board position 18 on which is
- 40 standing a chess piece 20. Each board position 18 will be substantially identical but for simplicity only 40
one is shown and described in connection with Figure 2. Beneath each board position is a transmit coil
22 made up of a number of turns of conducting wire and beneath that is a receiver coil 24 also made
up of a number of turns of wire. For example, the coil 22 can be 20 turns of 0.2 mm wire and the coil
24 can be 50 turns of 0.2 mm wire. The coils are as close to the underside of the board position as
- 45 possible, e.g. 2 to 3 mm below the surface. For good results we find that it is preferable that these coils 45
approximate the square shape of each board position and be about two-third's of the size of the board
position. The surface of the board is made up of a material which is permeable to electromagnetic
radiation e.g. wood which has the advantage of giving the board a traditional appearance.
- Figure 2 also shows a chessman 20 positioned on that board position. The chessman, like all of
- 50 the chessmen, has a hollow interior 26 within which is mounted an upright ferrite core 28. Around the 50
lower end of this core is provided a coil 30 made up of a number of turns of thin copper wire, e.g. about
150 turns of 0.2 mm enamelled wire, and mounted in series with the coils 30 is an adjustable
capacitor 32 (see Figure 2A), e.g. ranging from about 1 nF to about 22 nF.
- The inductance formed by the coils 30 and capacitor 32 form a tank circuit having a natural
- 55 resonant frequency and this resonant frequency can be finely adjusted by adjusting the capacitor 32 so 55
as to ensure that each chessman has its own characteristic resonant frequency which is sufficiently
different from all the other chessmen for it to be distinguished.
- By way of example there are a minimum of 12 chessmen which need to be separately
- 60 distinguished from one another, that is to say a king, a queen, a bishop, a knight and a castle and a 60
pawn of each colour. We find that these can be readily distinguished by spreading the resonant
frequency for each different piece over a range of say about 25 kHz to 200 kHz. The 12 frequencies are
desirably spread geometrically so as to give typical frequencies, numbers of turn in coil 30, and
capacitor 32 values as follows for the 12 pieces:

	<i>Chessman</i>	<i>Frequency (kHz)</i>	<i>Number of turns in coil 30</i>	<i>Capacitor 32 (nF)</i>	
	White Pawn	199.1	133	1.0	
	Black Pawn	170.0	156	1.0	
5	White Castle	145.2	183	1.0	5
	Black Castle	124.0	144	2.2	
	White Knight	105.9	169	2.2	
	Black Knight	90.5	161	3.3	
	White Bishop	77.3	158	4.7	
10	Black Bishop	66.0	185	4.7	10
	White Queen	56.4	149	10.0	
	Black Queen	48.2	174	10.0	
	White King	41.1	138	22.0	
	Black King	30.0	154	22.0	

15 Typically the tolerance of frequency can be of the order of about 5% and so, since there is a nominal spacing of about 17% between each adjacent pair of frequencies, this leaves a good safety margin to distinguish individual chessmen. 15

The ferrite core 28 acts as a flux concentrator for the inductance formed by the turns of the coils 30.

20 In order to determine the resonant frequency of a chessman placed in a particular board position, the transmit coil 22 is energised so as to emit a short pulse electromagnetic energy. This excites the coil 30 in the chessman by means of a normal transformer type action and sets the circuit in the chessman into oscillations at its natural resonant frequency. Then in turn the coil 30 emits radiation at its natural resonant frequency and this is detected by the receiver coil 24. 20

25 Turning now to Figure 3 this shows in diagrammatic form the various steps in this detection. The graph marked *a* shows the current signal pulse applied to the transmit coil 22. This is a single square pulse. 25

In the event that no chessman is present on the board position, the voltage signal received back and generated in the receiver coil 24 takes the form approximately of what is shown in the graph *b*. It will be noted that at the rising edge of the pulse in graph *a*, a signal is generated in the coil 24 and then another signal is generated at the falling edge of the pulse. 30

However in the event that a chessman such as the chessman 20 is standing on the board position, the coil 30 will receive energy from the pulse and the circuit in the chessman will be set into oscillation. In turn it will radiate an oscillating signal which can now be picked up by the receiver coil 24. The result is a "ringing" effect and the resulting voltage signal received by the receiver coil 24 is shown in graph *c*, the frequency of the ringing corresponding to the resonant frequency of the circuit of the particular chessman. 35

In graph *c* the area marked A of the resulting signal generated in the coil 24 by the rising edge of the transmitted pulse is not necessarily stable as regards frequency and so that area is discarded by the electronics of the apparatus as described below when detecting the frequency of the "ringing". In addition, the first complete oscillation marked B in graph *c* is also relatively unstable and so that is ignored by the electronics as described below. 40

Then the received signal from the coil 24 is amplified and limited so as to give a corresponding train of approximately square pulses as shown in graph *d*. At the same time the initial part of this signal corresponding to the area A of graph *c* is eliminated by blocking its passage whilst the current pulse shown in graph *a* operates. As a result the output shown in graph *e* is provided and this is fed to a first counter. 45

This first counter counts the wave train shown in graph *e* and provides outputs as shown in graph *f* at the second and fifth counts. These outputs are used to gate a main counter which therefore counts the oscillating signals fed to it from a clock signal or regular oscillating signal as shown in graph *g*. 50

It continues its count from the start of the second complete oscillation until the end of the fourth complete oscillation in the signal in graph *d* when the count is stopped. The resulting count is directly proportional to the frequency of the ringing or in other words to the natural resonant frequency of the chessman standing on the board position, the higher the frequency the shorter the count and the lower the frequency the longer the count. Therefore, the total count in the main counter can be used to determine the particular piece by comparing the count with a preset memory. 55

Of course, in the event that there is no piece standing on the board position as shown in graph *b*, the first counter will simply not reach the point C, see graph *f*, and so the main counter will not be started.

60 Having described the principle behind the detection of the presence or absence of a chessman on a board position and the determination of which chessman is present if appropriate, reference will now be made to Figure 4 which shows in diagrammatic form, circuitry which can be used to detect the position of all the chessmen currently on the board in the manner described above. 60

To simplify the electronic circuitry so that one single discriminator circuit can be shared by all of the 64 board positions, the energizing of the transmit coils 22 is multiplexed. In addition, we have found it desirable to multiplex simultaneously the receiver coils 24 for all the board positions. Full multiplexing of the two sets of coils is preferred so that only one transmit coil and the corresponding receiver coil are energised at any time. This also enables one to reduce radio frequency interference.

Referring to Figure 4 the transmit coils 22 are connected in parallel in eight columns of eight coils. They need not be so connected however, and instead they could be split into two groups of four, each coil in each group being connected in series and, along each column, the coils being alternately in one or the other group.

Thus those transmit coils 22 given the board positions 1, 3, 5 and 7 in a column could be connected in series whilst the coils given the board positions 2, 4, 6 and 8 could in turn be connected in series. This arrangement minimizes the effects of interference between adjacent squares since only alternate transmit coils in any column are pulsed at any one time.

To achieve multiplexing, the transmitter coils 22 are in turn connected by analogue switches 50 and 55 to a pulse generating circuit 53 for pulsing on a square scan. Thus, each column is in turn provided with the pulses when the switch makes transistors 52 in series with each column conductive and in turn each coil 22 in each column is selectively energised in turn when a diode 23 in series with each coil is made conductive by the switch 55. In this way only a single coil 22 is energised at any one time.

The receiver coils 24 are multiplexed by means of analogue switches 54 and 50 so as to connect each coil 24 in turn to the discriminator circuit. Each coil 24 is connected at one end to a row bus each of which is activated in turn from the switch 50 and each coil is connected in series through a respective diode 58 to a column bus which is in turn controlled by the switch 54. Thus each coil 24 is in turn checked by simultaneously in synchronism with the pulsing of its respective coil 22 applying across the coil a voltage from the appropriate column and the appropriate row bus to make the associated diode 58 conductive and the resulting output detected in that coil is fed by the appropriate row bus through the switch 54 to its output pin 3 and to the discriminator circuit.

A discriminator circuit 56 (see Figure 5) receives the signal from the respective receiver coils 24 and amplifies this by means of a transistor 62. The amplified signal then passes to a comparator 64 which "slices" the AC signal to give a symmetrical square wave output. In turn, the output passes to a decade counter 65 whose output gates the counting of a binary 12-stage counter 66, starting the count of the counter 66 when the counter 65 reaches its second count and stopping it when it reaches the end of the fourth count. A crystal oscillator 68, e.g. of 2 MHz frequency, provides an oscillating signal which is counted by the binary counter 66.

The resulting count from the counter 66 is, as explained above, directly proportional to the resonant frequency of the particular chessman and so the output from the counter is passed to a latch 72 (see Figure 5) in which the count is compared with the information stored in that latch to determine which chessman is on that board position.

In the event that no chessman is present above the receiver coil 24 linked to the discriminator circuit, then of course only a single pulse will be received by the decade counter 65 and it will not reach the point of a second pulse where it will allow the counter 66 to start its counting. Therefore, the absence of a chessman can be recognised by finding a zero count on the counter 66.

The strobing circuit arranges for each board position to be checked sequentially and for the check to continue all the time when the board is operating so that any changes in the positions of chessmen are immediately noted.

Referring to Figure 5 which shows the general arrangement of the circuitry to control the game, the output from the latch 72 can be used to pass information directly to a game microprocessor 82 which retains the up-to-date position of each chessman and which is preprogrammed with criteria to enable the game to select an appropriate response move in answer to a move made by a player. Suitable game microprocessors are well known and are used in electronic computer games of the type which we have sold for example under the trade names Chess Champion Traveler, Chess Champion Pocket Chess, Chess Champion Super System III, Chess Champion Super System IV, Graduate Chess, Executive Chess and Senator Chess.

In order to show to a player the game's response to a player's move, an output 84 is provided. For example, each board position may be provided with a small transparent section 90 beneath which is mounted a small lamp or LED 92 (see Figure 2) or alternatively a liquid display unit. This lamp is illuminated in the square on which the piece to be moved currently stands and a similar lamp is illuminated in the square to which the piece is to be moved. In this way, the game microprocessor 82 can show the player the move which it has chosen in response to the player's move and the player moves the piece according to those instructions. Once the board senses that the move has been correctly completed, the two lamps can be extinguished. As an alternative the entire square on which the chessman is standing could change e.g. become lighter or darker by using electro-lighting techniques. This technique could be particularly useful for instruction in a game so illuminating a number of possible board positions to show optional moves or threatened pieces.

There are however many alternative manners of showing the games response moves and providing the output 84. Thus, for example, the board positions can be identified by coordinates, e.g. A

to H for the rows and 1 to 8 for the columns, and the box 12 provided with a display in which the coordinates of the initial and final positions of a chess piece to be moved are displayed.

Other possible ways of showing the boards response include the direct movement of the actual chessmen across the surface of the board by means of a robot arm controlled by the board itself or by electromagnetic means from beneath the board. Alternatively the computer may be provided with a computer voice and the output moves indicated verbally so indicating to the player which piece to pick up and where to move it. Further a completely separate visual display could be provided on which the game could indicate the desired move by words or pictures on a completely separate display panel from the board.

Finally the board need not form part of the full game but could be sold separately and merely used as an interface between the human player and the game processor. In this respect the board would be analogous to a TV screen used with separately sold electronics for playing a video chess game. Thus the board could operate purely in a slave mode to accept reply moves from the game processor and to inform the latter of input moves made by the player and then the board should be made so as to be compatible with existing electronic units for video games.

The clock 94 is shown in Figure 5 as forming part of the game microprocessor 82. A separate clock including the crystal oscillator 68 is shown in Figure 4. Either is possible.

Figures 6 and 7 show a modified board 100 in which a single coil 102 acts both as the transmitter coil 22 in Figure 2 and the receiver coil 24 in Figure 2. This is possible because the separate receiver coil does not have a part to play during the transmission of a pulse and equally the separate transmitter coil does not have a part to play during reception of a pulse. Thus, referring to Figure 3, this can be seen by comparing graphs *a* and *c* since the portion A of graph *c* is ignored. Therefore in the board 100 a single coil 102 of 20 turns of wire is placed under each of the squares of the board.

During transmission of a pulse the coil demultiplexer 104 connects the coil to a ramp current generator 106 and driver 108 so that the transmitter coil receives the pulse for transmission and during reception the demultiplexer 104 connects the coil 102 so that the received signal is passed to an amplifier 110 and onto a discriminator 112 which functions in a manner similar to that described in connection with figures 3 to 5 to determine the presence or absence of a chess piece on the respective square and if a piece is present the nature of that piece.

In this board 100 a square shaped transmission pulse is not supplied to the coil 102 as for the coil 22 shown in Figures 2 and 3. Instead the pulse is a ramp pulse having a progressively increasing front and an abrupt trailing edge since it is the effect of the trailing edge of the pulse which is monitored by the receiver.

The board 100 has the advantages that it can be of lower cost because of the simplification of the coils and elimination of certain circuitry and because of ease of assembly because a smaller number of connections are required. Also the board produces a lower unwanted noise signal.

Although the invention has been described in connection with a chess board, the invention could be used with any form of board game, for example "Shogi" (Japanese chess), "Go", or cross-word games such as that sold under the trade name "Scrabble" (registered).

40 Claims

1. A board for a board game having a surface on which playing pieces are arranged to be moved by players over a range of discrete board positions according to the rules of the game, each playing piece being provided with an electrical resonant circuit whose frequency is distinguishable from other discrete pieces, each discrete board position being provided with a transmitter capable of emitting a pulse of electromagnetic radiation to induce resonance in the resonant circuit of a piece positioned on that board position, and with a receiver for detecting the presence or absence of returning electromagnetic resonant radiation depending upon whether or not a piece is positioned on that board position, a discriminator for determining the resonant frequency or lack of resonant frequency received by the receivers to determine the nature of the particular piece or absence of a piece on that discrete board position, means for storing the up-to-date board positions of each piece on the board, and means for determining a move made by a player moving a piece from one board position to another.

2. A board as claimed in Claim 1 in which in each piece the electrical resonant circuit is constituted by an inductor and capacitor joined in a tank circuit, the resonant frequency of each distinct piece differing from each other piece.

3. A board as claimed in Claim 2 in which the loop is wound around an upright ferrite core in the piece.

4. A board as claimed in any preceding claim in which the transmitter and receiver are each in the form of separate electrical coils.

5. A board as claimed in Claim 4 in which at each board position the transmitter coil is positioned above the receiver coil adjacent to the underside of the board.

6. A board as claimed in any preceding claim in which the transmitters and receivers of the respective board positions are energised in turn by multiplexing, and a single discriminator circuit is provided.

7. A board as claimed in Claim 6 in which rows or columns of the receiver coils are connected in

parallel and series with each coil is a diode, means being provided to multiplex in turn the coils connected in parallel in a row or column to make conductive one at a time the diodes in those coils connected in parallel in a row or column.

- 5 8. A board as claimed in Claim 6 or Claim 7 in which rows or columns of the transmitter coils are
connected in parallel and in series with each coil is a diode, means being provided to multiplex in turn 5
the coils connected in parallel in a row or column and to make conductive one at a time the diodes in
those coils connected in parallel in a row or column.
9. A board as claimed in any of claims 1 to 3 in which a single coil at each board position
functions both as the transmitter and the receiver.
- 10 10. A board as claimed in Claim 9 in which coils of the respective board positions are energised in 10
turn by multiplexing and a single discriminator circuit is provided.
11. A board as claimed in any preceding claim in which the pulse of radiation has a progressively
increasing front edge on an abrupt trailing edge, the effect of this abrupt trailing edge inducing
resonance in the resonant circuit.
- 15 12. A board as claimed in any preceding claim in which the discriminator determines the 15
frequency received by the receiver by determining the time span of a set of number of received
oscillations.
13. A board as claimed in Claim 12 in which the said time span is determined from the circuit
from the count made by a counter fed with regular pulses from an oscillator which is switched on at a
20 particular receiver oscillation and switched off after a set number of received oscillations. 20
14. A board substantially as herein described with reference to Figures 1 to 5 of the
accompanying drawings.
15. A board substantially as herein described with reference to Figures 6 and 7 of the
accompanying drawings.
- 25 16. A board game comprising a board as claimed in any preceding claim and means for selecting 25
and indicating the game's response move to a move made by a player according to preselected criteria
stored in the game's memory.
17. A board game comprising a board on the surface of which playing pieces are arranged to be
moved by players over a range of discrete board positions according to the rules of the game, each
30 playing piece being provided with an electrical resonant circuit whose frequency is distinguishable from 30
other discrete pieces, each discrete board position being provided with a transmitter capable of
emitting a pulse of electromagnetic radiation to induce resonance in the resonant circuit of a piece
positioned on that board position, and with a receiver for detecting the presence or absence of
returning electromagnetic resonant radiation depending upon whether or not a piece is positioned on
35 that board position, a discriminator for determining the resonant frequency or lack of resonant 35
frequency received by the receivers to determine the nature of the particular piece or absence of a
piece on that discrete board position, means for storing the up-to-date board positions of each piece on
the board, means for determining a move made by a player moving a piece from one board position to
another, and means for selecting and indicating the game's response move to a move made by a player
40 according to preselected criteria stored in the game's memory. 40
18. A board game substantially as herein described with reference to Figures 1 to 5 of the
accompanying drawings.
19. A board game substantially as herein described with reference to Figures 6 and 7 of the
accompanying drawings.